

WIS-EAP530B

11AX 3000Mbps Wi-Fi6 Enterprise Ceiling AP

WIS-EAP530B IS a 11AX Wi-Fi standard Qualcomm Chipset high power industrial Ceiling Wireless Access Point support MU-MIMO, Wave2.0, OFDMA and Seamless Roaming with integrates Bluetooth LE (vBLE) and Internet of Things (IoT) capabilities to deliver unprecedented user experiences. Combined 3000Mbps Wi-Fi speed over 2 radios: 2.4GHz (600Mbps 11ax 2*2) + 5GHz (2400Mbps 2*2), equipped Gabit LAN Ports, support MU-MIMO and DL/UL-OFDMA modulation, Giga Ethernet data rate and more users, then multiple users can upload or download multiple packets at same time, narrower subcarrier spacing and longer symbol time, improved the stability and data processing efficiency, publicly to be used in high density access environment such as university campus, concert venue, hotels, corporates etc.

Superior performance guarantee

WIS-EAP530B with Qualcomm industrial chipset and adapt to intelligent channel analysis technology choose the less Wi-Fi interference channel makes wireless transmission faster and more stable.

Multiple Protection for Stable Performance

WIS-EAP530B with ABS fireproof material, white color, suitable for various decoration styles. And PCB board with watchdog design, can reboot automatically in case of failure. What's more, it support lightning protection and ESD protection, can install in various harsh environment.

TWT (Target Wake-up Time)

802.11ax support TWT, allowing devices to negotiate when need to wake up, send and receive data. In additional, wireless AP can group the device into different TWT cycles, increase sleep time, reduce the device competing a tier wake-up, and save the device power.

High-Speed Dual Band Wi-Fi 6

WIS-EAP530B equips with the latest wireless technology, Wi-Fi 6, for faster speeds, greater capacity, and reduced network congestion. Wi-Fi 6 (IEEE802.11ax) delivers a huge boost in speed and total capacity and takes your Wi-Fi to the next level while being backwards compatible with IEEE802.11ax/ac/b/g/n/a Wi-Fi standards, optimized for Internet activities requiring high bandwidth, such as HD videos and online gaming



Features

- Dual band, 11ax/ac/b/g/n/a with 3000Mbps data rate.
- Bluetooth 5.0 internal Inbuilt
- 11ax 2x2 MU-MIMO support.
- 1*10/100/1000Mbps Ethernet Ports.
- Allow 150+ concurrent users to access into the networking;
- With external power amplifier design, more RF power, more wireless coverage;
- Support 160MHz bandwidth, faster speed in UL and DL;
- Support Seamless roaming, TWT, OFDM...



Superior performance guarantee

WIS-EAP530B with Qualcomm industrial chipset and adapt to intelligent channel analysis technology chose the less Wi-Fi interference channel makes wireless transmission faster and more stable.

TWT (Target Wake-up Time)

802.11ax support TWT, allowing devices to negotiate when need to wake up, send and receive data. In additional, wireless AP can group the device into different TWT cycles, increase sleep time, reduce the device competing after wake-up, and save the device power.

High-Speed Dual Band Wi-Fi 6

WIS EAP-530B equips with the latest wireless technology, Wi-Fi 6, for faster speeds, greater capacity, and reduced network congestion. Wi-Fi 6 (IEEE802.11ax) delivers a huge boost in speed and total capacity and takes your Wi-Fi to the next level while being backwards compatible with IEEE802.11ax/ac/b/g/n/a Wi-Fi standards, optimized for Internet activities requiring high bandwidth, such as HD videos and online gaming.

1024-QAM Modulation Mode

DL/ UL MU-MIMO 802.11ax support both downlink MU-MIMO and uplink MU-MIMO. It can communicate with multiple end users at the same time, greatly improving the user's uplink transmission rate and the system's uplink and downlink capacity, improving the efficiency of multi-user concurrent scenarios, and reducing the terminal application latency.

DL/ UL MU-MIMO

11ax supports both downlink MU-MIMO and uplink MU-MIMO. It can communicate with multiple end users at the same time, greatly improving the user's uplink transmission rate and the system's uplink and downlink capacity, improving the efficiency of multi-user concurrent scenarios, reducing the terminal application latency.

Coverage Improvement

802.11ax support long OFDM symbol transmission mechanism and 2MHz narrowband transmission, effectively reduced the packet loss rate and noise interference, improve the receive sensitivity and increase the WiFi coverage.

Watchdog design, No internet lose

The watchdog chip + circuit design make the equipment with selfinspection in network disconnection, link detection and network backup. When it found that device is disconnected, the watchdog circuit will restart the system automatically to ensure the reliability and safety.

Long wireless coverage

Transfer all kinds of data smoothly ,do not have any latency.WIS-EAP530B is a high power Ceiling wireless with 150+ meters wireless range ,can meet the demands for outdoor wifi project large area coverage, specialize in high power design ,can ensure strong wireless signal and stable performance.

Three ways of WIS Controller Solution

All configuration and management is centrally and effectively operated by WIS cloud Controller. Deploy wiscloud AP and scale up easily with any one of the controller.

[Cloud Controller](#) | [App Based Controller](#) | [Hardware Controller](#)

Multiple Application Scene

WIS-EAP530B Gigabit ceiling wireless AP can be used for indoor environment where need wireless coverage like Park,School,Mall Scenic point,university campus, concert venue,hotels,corporates etc.



SPECIFICATION

Model	WIS-EAP530B
Chipset	Qualcomm
Standard	802.11ax/ac/b/g/n/a
Bluetooth 5.0	vBLE Directional Antenna Array + Omni Bluetooth Antenna
Flash	SPI NOR 8MB (1.8v) + NAND 128MB
DDR3L	512MB
2.4G Frequency	2.4GHz- 2.484GHz
2.4G Wi-Fi standard	802.11b/g/n/ax
5.8G Frequency	4.9~5.9G
5.8G Wi-Fi Standard	802.11 a/n/ac/ax
Interface	1 * 10/100/1000Mbps RJ45 WAN port and PoE port, 1 * Reset button, press 10 seconds to revert to default setting
Antenna	Build in 4*4dBi dual band MIMO Antenna
Data Rate	3000Mbps (2.4G 600Mbps, 5.8G 2400Mbps)
End Users	150
2.4G RF Power	≤ 23dBm
5.8G RF Power	≤ 23dBm
DC	12V---2A
PoE	48V (IEEE 802.3at)
LED light	Sys, WAN, LAN
Power Consumption	≤ 20W
Size	TBD
Working Mode	Gateway, AP
Wireless Functions	Multiple SSID functions: 2.4GHz: 4; 5.8GHz: 4. Support SSID hidden Support seamless roaming, 802.11kvr standard. Support 5G Prior for a faster Ethernet. Wireless Security: Open, WPA, WPA2PSK_TKIPAES, WAP2_EAP, WPA3 Support MAC filter Support Wi-Fi time on/off to save energy Support client isolation to improve the wireless stability Support RF power adjustable, adjust the RF power based on environment. Support user quantity limited, Max 64 users to access each band.
Networking Function	VLAN settings Cloud access support in gateway mode
Device Management	Back-up the configuration Restore the configuration Reset to factory default Reboot the device: including time reboot or reboot immediately Admin management password modify Firmware upgrade System log Support firmware GUI web management, AC controller management, remote management and Cloud management



Antenna Specification

Frequency Range	2.4GHz & 5.8GHz
Impedance	50 Ohms nominal
Gain	4dBi
Radiation	Omni
Polarization	Vertical

Packaging Information:

1* WIS-EAP530
1* Mounting Kit
Quick Installation Guide
Gift Box

DIMENSIONS

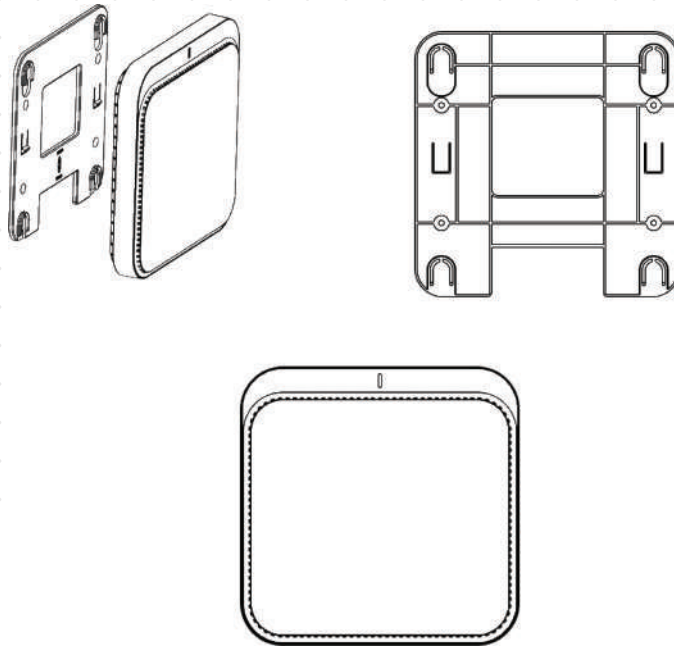

ORDERING INFORMATION

WIS-EAP530B

11AX 3000Mbps DUAL Band Wi-Fi6 Enterprises AP with bluetooth

